

Dedicated Controls

Installation and operating instructions



English (GB) Installation and operating instructions

Original installation and operating instructions.

CONTENTS

	Page
1. Symbols used in this document	3
2. Scope of these instructions	3
3. Identification	3
3.1 Nameplate	3
3.2 Type key	4
4. Installation	5
4.1 Mechanical installation	5
4.2 Electrical installation	5
4.3 EMC and earthing	6
4.4 Schematic system overview	7
5. Standard configuration	9
5.1 CU 361	9
5.2 IO 351B	10
5.3 Float switches	11
5.4 Float switch connection	12
5.5 Analog level sensors	13
5.6 Communication	14
6. Commissioning	15
6.1 Start-up	15
6.2 Taking Dedicated Controls out of operation	15
6.3 Quick start	15
6.4 I/O settings	19
6.5 Electrical overview	22
7. Maintenance	23
7.1 CU 361	23
8. Fault finding	24
9. Technical data	25
10. Electrical data	25
11. Disposal	25



Warning

Prior to installation, read these installation and operating instructions. Installation and operation must comply with local regulations and accepted codes of good practice.

1. Symbols used in this document



Warning

If these safety instructions are not observed, it may result in personal injury!



Caution

If these safety instructions are not observed, it may result in malfunction or damage to the equipment!

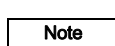

Note

Notes or instructions that make the job easier and ensure safe operation.

2. Scope of these instructions

These installation and operating instructions apply to Grundfos wastewater pits with a Grundfos Dedicated Controls system. The Dedicated Controls system is designed to drain a wastewater pit with up to six pumps.

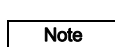

Note

The Dedicated Controls system cannot be used to fill a tank or reservoir.

The subcomponents in the control cabinet are only described in these instructions when they are important for the operation of the Dedicated Controls system.

Further documentation supplied with the Dedicated Controls:

- Safety instructions for Dedicated Controls
- Quick guide for Dedicated Controls
- Dedicated Controls support CD-ROM
 - these installation and operating instructions
 - Software description
 - additional instructions (CU 361, IO 351B, IO 111, CIM 2XX, etc.)
 - functional profiles
 - PC Tools.

3. Identification

3.1 Nameplate

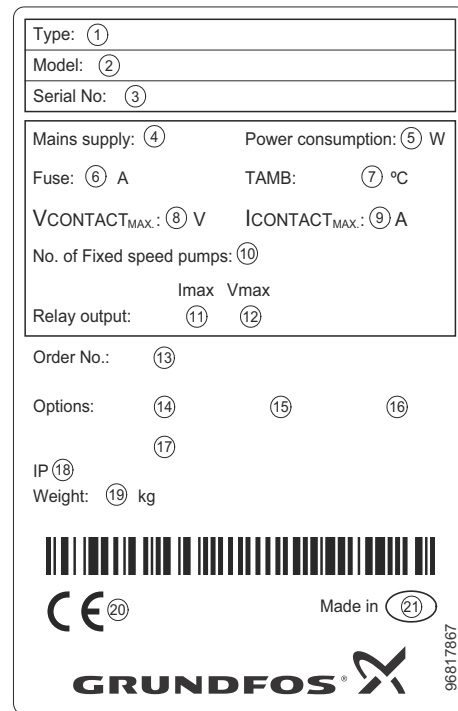

Fig. 1 Nameplate, Dedicated Controls control cabinet

Pos.	Description
1	Type designation
2	Model (optional)
3	Serial number
4	Mains supply
5	Power consumption
6	Fuse
7	T _{amb.}
8	V _{contact max.}
9	I _{contact max.}
10	Number of fixed-speed pumps
11	I _{max.} , relay output
12	V _{max.} , relay output
13	Order number
14-17	Options
18	Enclosure class
19	Weight in kg
20	CE mark
21	Country of origin

TM04 3790 5008

3.2 Type key

Example	DCD	318	400	3	23	DOL	-IGM
Number of pumps							
DC: One pump							
DCD: Two pumps							
Type number							
318: Control cabinet without main switch							
319: Control cabinet with main switch							
Supply voltage and frequency							
230: 230 V, 50/60 Hz							
400: 400 V, 50/60 Hz							
Number of phases							
1: Single-phase							
3: Three-phase							
Maximum current per pump [A]							
1: 1 - 1.5							
2: 1.5 - 2.5							
4: 2.5 - 4							
5: 1 - 5							
6: 4 - 6							
10: 6 - 10							
12: 5 - 12							
16: 10 - 16							
20: 5.5 - 20							
23: 12 - 23							
25: 20 - 25							
30: 10 - 30							
32: 25 - 32							
40: 32 - 40							
50: 40 - 50							
57: 40 - 57							
58: 50 - 58							
59: 15.5 - 59							
65: 55 - 65							
75: 65 - 75							
85: 15.5 - 85							
100: 70 - 100							
Run/starting capacitor [µF] (only 12 A operating current)							
[: Without capacitor							
30: Run capacitor							
30/150: 30 µF run capacitor and 150 µF starting capacitor							
Starting method							
DOL (Direct On Line): Direct-on-line starting							
SD: Star-delta starting							
SS: Soft starter							
Setup							
S: Standard							
I: IO 111 (both pumps)							
G: GSM module and battery backup							
M: Mixer/flush valve							
IG: IO 111, GSM module and battery backup							
IM: IO 111 and mixer/flush valve							
GM: GSM module, battery backup and mixer/flush valve							
IGM: IO 111, GSM module, battery backup and mixer/flush valve							

4. Installation



Warning

Installation and operation must comply with local regulations and accepted codes of good practice.

Before installation, check the following:

- Do the specifications of the Dedicated Controls system correspond to the order?
- Are all visible parts intact?

4.1 Mechanical installation

This section describes the mechanical installation of the Dedicated Controls control cabinet and also provides general advice about how to position sensors in order to achieve stable measured values.

4.1.1 Dedicated Controls

The control cabinets incorporate a CU 361 control unit connected to one or two IO 351B modules. An optional IO 111 sensor module can be connected to each pump.

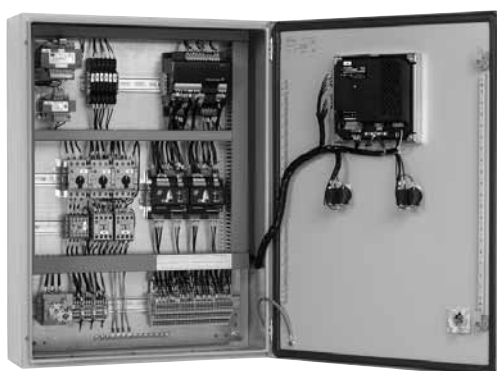

Fig. 2 Example of Dedicated Controls control cabinet

The CU 361 is the 'brain' of the system and must be incorporated in all systems. The units in the system can be combined in different ways according to the user's needs.

The control system controls the pumps by means of contactors and IO 351B modules. Contactors, cables and other high-voltage components should be positioned as far away as possible from the control system and the signal cables.

The control system is operated via a user-friendly control panel on the CU 361 or via a PC. Wireless remote control is available throughout the world, using a PC or mobile phone. The control system can be integrated into a user's existing SCADA system.

A specially developed PC program can be used to configure and subsequently monitor and maintain the system.

The control system can communicate in many different ways, for example with a SCADA system. Grundfos offers various fieldbus CIM communication modules that can be fitted in the CU 361. The type of protocol and line carrier being used must be taken into consideration when selecting the correct module.

4.1.2 Sensors

The Dedicated Controls system requires correctly measured values in order to give an accurate indication of the pit status. It is therefore important to position and install sensors according to the manufacturer's instructions.

General requirements

The sensors must always be correctly sized for the range they are to measure. If the sensor is too small, it will be saturated. If it is too big, the resolution of the sensor signal will be too poor.

4.2 Electrical installation

The electrical connection should be carried out by an authorised electrician in accordance with local regulations.



Warning

Before making any electrical connections, make sure that the power supply has been switched off and that it cannot be accidentally switched on.

The following sections are intended as a supplement to the wiring diagram supplied with the Dedicated Controls control cabinet.

The terminal blocks shown in section 4.2.1 *Terminal blocks* apply to an application with two pumps (DCD 318).

4.2.1 Terminal blocks

Terminal block for the mains supply

- Connect the mains supply cable to terminal block X1.

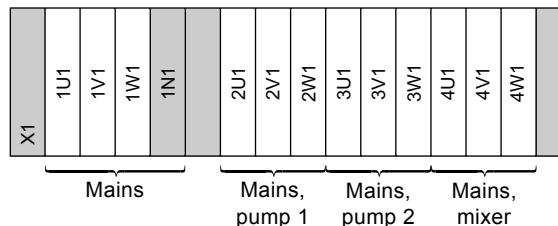

Fig. 3 Terminal block X1, mains supply

- Connect the supply cables for each pump and the mixer, if installed. The mixer is optional.

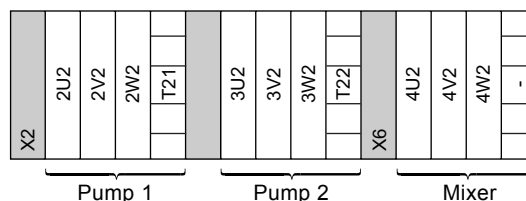

Fig. 4 Terminal blocks X2 and X6, mains supply

Control signals

The system is controlled by various sensors, modules and relays connected to these inputs and outputs:

- AI (analog input)
- DI (digital input)
- AO (analog output)
- DO (digital output).

TM04 6417 0310

TM04 5777 3909

TM04 6418 0310

Terminal block for the IO 351B

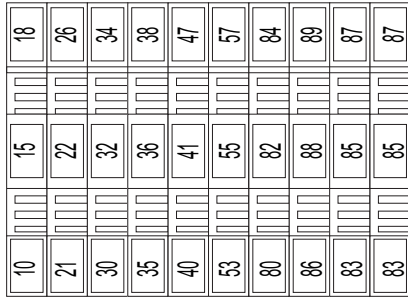

Fig. 5 Terminal block X3, IO 351B

TM04 6419 0310

Terminal block X3, IO 351B

Terminal	Input type	Terminal	Input type	Terminal	Input type
10	DI1	15	GND	18	AO4
21	GND (AO)	22	AO5	26	AO6
30	PTC1	32	PTC2	34	PTC3
35	GND (PTC)	36	PTC4	38	PTC5
40	PTC6	41	GND (PTC)	47	GND (AO)
53	24 V	55	GND	57	AI1
60	AI2	82	DO4, NO	84	DO5, NO
86	DO6, NO	88	DO7, NO	89	DO7, C
83	DO4, C	85	DO5, C	87	DO6, C
83	DO4, C	85	DO5, C	87	DO6, C

Terminal block for the CU 361

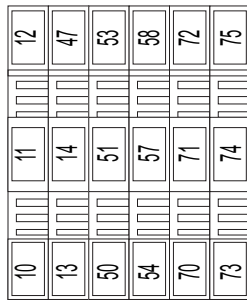

Fig. 6 Terminal block X4, CU 361

TM04 6420 0310

Terminal block X4, CU 361

Terminal	Input type	Terminal	Input type	Terminal	Input type
10	DI1	11	GND	12	DI2
13	GND	14	DI3	47	+24 V
50	+24 V	51	AI1	53	+24 V
54	AI2	57	AI3	58	GND
70	DO5, C	71	DO6, NO	72	DO6, C
73	DO6, C	74	DO7, NO	75	DO7, C

Terminal block for the IO 111

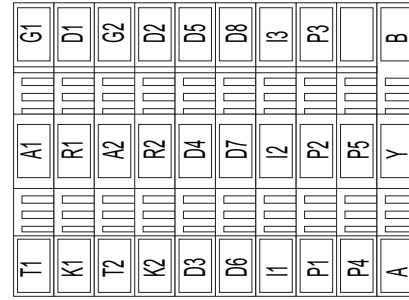

Fig. 7 Terminal block X7, IO 111

TM04 6422 0310

Note For the connection of the IO 111 module, see the installation and operating instructions for the IO 111.

In the following sections, two examples are shown:

- Two pumps with analog level sensor and safety float switches. See section 4.4.1.
- Two pumps with five float switches. Special application that requires special wiring in the control cabinet. See section 4.4.2.

Supply voltage

Unit/module	VAC	VDC
CU 361	1 x 100-240 VAC ± 10 %, 50/60 Hz, PE (Class 1 equipment)	Battery +12 VDC
IO 351B	1 x 100-240 VAC ± 10 %, 50/60 Hz, PE (Class 1 equipment)	-
IO 111	24 VAC ± 10 %, 50 and 60 Hz	24 VDC ± 10 %

4.3 EMC and earthing

If there is a risk of electrical noise, the CU 361 and the modules in the control cabinet should be earthed. This is achieved using screws on a metal back plate, which is earthed with the best possible earth connection. This must be done for personal safety and as protection against undesired electrical noise.

Signal cables must be earthed appropriately. The optimum solution is to fit a clamp to the electrically conducting back plate so that it lies over the cable and is in contact with the cable screen.

Caution Each pump must be connected to a separate motor protector or similar protection.

4.4 Schematic system overview

4.4.1 Two pumps with analog level sensor and safety float switches

Figure 8 shows an example of a two-pump installation with an analog level sensor (AI1, CU 361). The system has two safety float switches, i.e. for high level (DI2, CU 361) and for dry running (DI1, CU 361). A flowmeter has been installed in the discharge line. The flowmeter is both connected to an analog input (AI2, CU 361) for actual flow measurement and to a digital input (DI1, IO 351B) set up as a counter input (flowmeter).

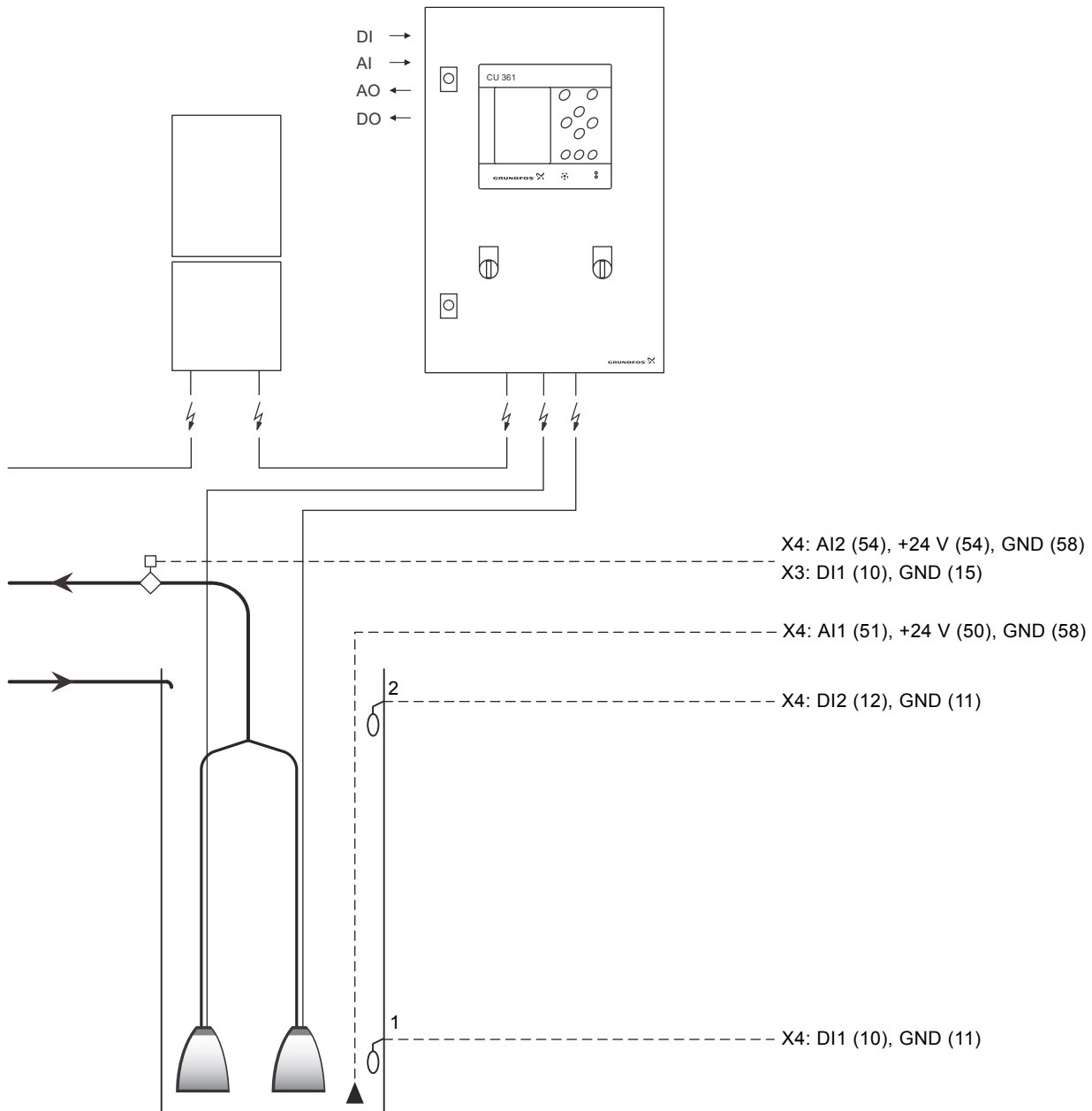

Fig. 8 Two pumps with analog level sensor and safety float switches

Float switch	Unit	Terminal block	Signal (terminal)	Description
Float switch 2	CU 361	X4	DI2 (12), GND (11)	High level
Float switch 1			DI1 (10), GND (11)	Dry running
Sensor	Unit/module	Terminal block	Signal (terminal)	Description
Level sensor	CU 361	X4	AI1 (51), +24 V (50), GND (58)	Level measurement
Flowmeter	CU 361	X4	AI2 (54), +24 V (54), GND (58)	Actual flow measurement
	IO 351B-1	X3	DI1 (10), GND (15)	Flowmeter (total volume)

4.4.2 Two pumps with five float switches

Figure 9 shows an example of a two-pump installation controlled by five float switches. Two float switches are used as safety float switches, i.e. for high level (DI2, CU 361) and for dry running (DI1, CU 361). The last three float switches are used to start and stop the pumps, i.e. Start 1 (DI9, IO 351B), Start 2 (DI8, IO 351B) and Stop (DI3, CU 361). A pressure sensor (AI2, CU 361) has been installed in the discharge line close to the collection point of the pipes.

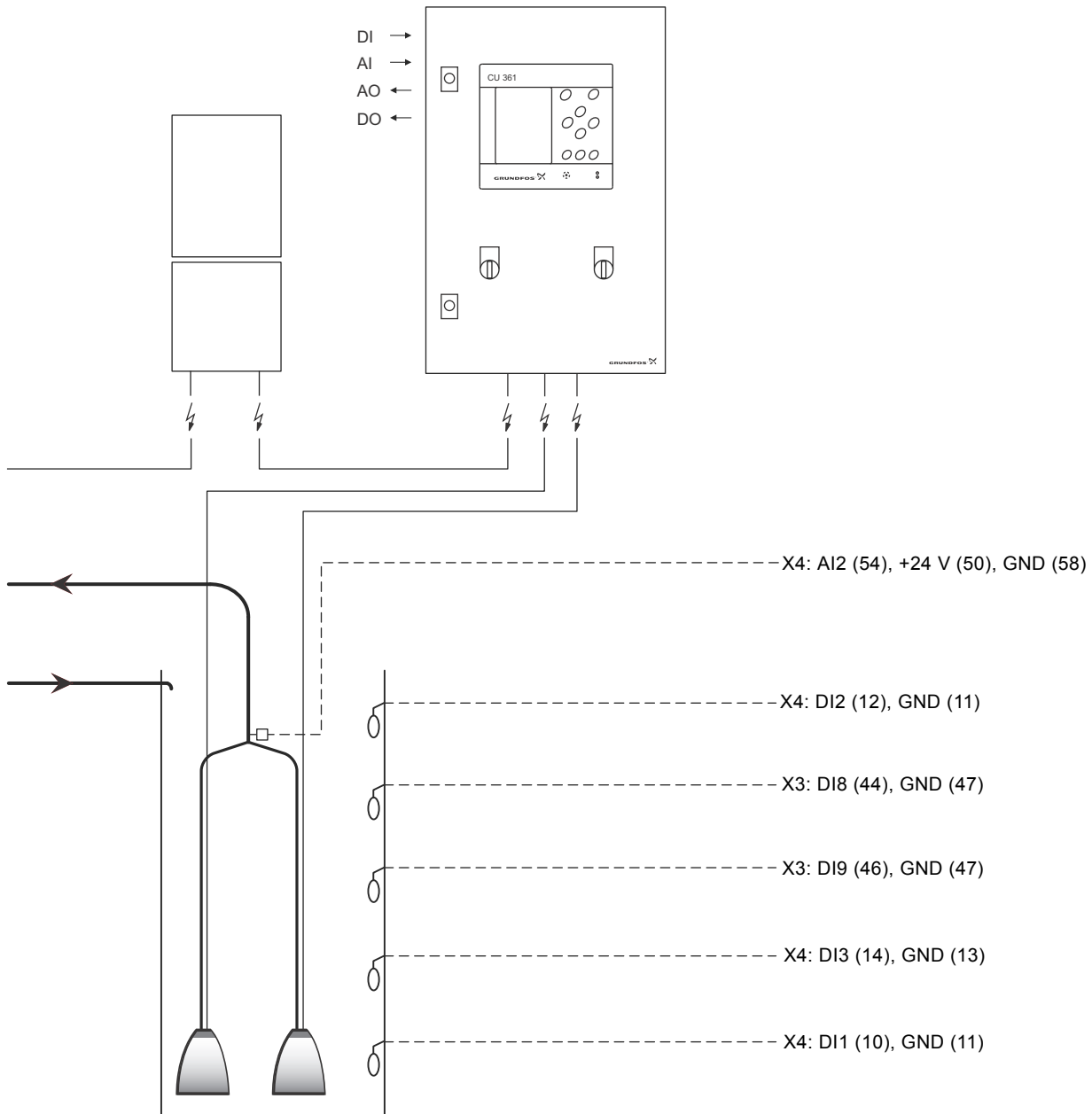

Fig. 9 Two pumps with five float switches

Float switch	Unit/module	Terminal block	Signal (terminal)	Description
Float switch 5	CU 361	X4	DI2 (12), GND (11)	High level
Float switch 4	IO 351B-1	X3	DI8 (44), GND (47)	Stop 2
Float switch 3	IO 351B-1		DI9 (46), GND (47)	Start 1
Float switch 2	CU 361	X4	DI3 (14), GND (13)	Stop
Float switch 1	CU 361		DI1 (10), GND (11)	Dry running

Sensor	Unit	Terminal block	Signal (terminal)	Description
Pressure sensor	CU 361	X4	AI2 (54), +24 V (50), GND (58)	Discharge pressure measurement

5. Standard configuration

AI	Analog input	Configuration of analog inputs. See section 6.4.1 Analog inputs .
DI	Digital input	Configuration of digital inputs. See section 6.4.2 Digital inputs .
AO	Analog output	Configuration of analog outputs. See section 6.4.3 Analog outputs .
DO	Digital output (relay output)	Configuration of digital outputs. See section 6.5.4 Digital outputs .
PTC	Positive Temperature Coefficient	-

5.1 CU 361

CU 361	Description	Inputs and outputs
 <p style="text-align: center; font-size: small;">GRA6588</p>	<p>The CU 361 is the 'brain' of the Dedicated Controls system and is mounted in the control cabinet front.</p> <p>The CU 361 can control and monitor up to six Grundfos wastewater pumps. The pumps can drain a pit using built-in draining algorithms. The algorithms are based on a water level measured by float switches or an analog level sensor.</p>	<p>CU 361 inputs and outputs:</p> <ul style="list-style-type: none"> • GENIbus communication (RS-485) • 3 analog inputs for connection to sensors with current (0-20 mA/4-20 mA) or voltage (0-10 V) • 3 digital inputs • 2 digital outputs, 240 VAC, 2 A • Connection to battery backup (UPS) (optional) • Ethernet connection (VNC) • Connection to fieldbus CIM modules (CIM = Communication Interface Module): <ul style="list-style-type: none"> – CIM 200 (Modbus via RS-485) – CIM 250 (Modbus and SMS via GSM/GPRS) – CIM 270 (GRM) (GRM = Grundfos Remote Management).

Level control and safety

Signal	Terminal	Float switch	Analog sensor	Analog sensor and safety float switches	Analog sensor and mixer	Analog sensor, mixer and safety float switches
Analog inputs						
AI1	51	-	Level sensor	Level sensor	Level sensor	Level sensor
AI2	54	-	Flow sensor	Flow sensor	Flow sensor	Flow sensor
AI3	57	-	User-defined sensor 1	User-defined sensor 1	User-defined sensor 1	User-defined sensor 1
Digital inputs						
DI1	10	Float switch*	-	Dry-running float switch	-	Dry-running float switch
DI2	12	Float switch*	-	High-level float switch	-	High-level float switch
DI3	14	Float switch*	-	-	Mixer feedback	Mixer feedback
Digital outputs						
DO1 (NO)	71	High-level alarm	High-level alarm	High-level alarm	High-level alarm	High-level alarm
DO1 (NC)	72	-	-	-	-	-
DO2 (NO)	74	All alarms and warnings	All alarms and warnings	All alarms and warnings	All alarms and warnings	All alarms and warnings
DO2 (NC)	75	-	-	-	-	-

* See section [5.3 Float switches](#).

5.2 IO 351B

IO 351B	Description	Inputs and outputs
 <p>TM03 2110 3705</p>	<p>The IO 351B is a general I/O module.</p> <p>The IO 351B communicates with the CU 361 via GENIbus.</p> <p>Via the IO 351B inputs and outputs, the CU 361 controls the pumps according to the built-in algorithms.</p>	<p>IO 351B inputs and outputs:</p> <ul style="list-style-type: none"> • GENIbus communication (RS-485) • 2 analog inputs for connection to sensors with current (0-20 mA/4-20 mA) or voltage (0-10 V) • 9 digital inputs • 7 digital outputs, 240 VAC, 2 A • 4 PTC inputs.

Level control and safety

Module	Signal	Terminal	Float switch	Analog sensor	Analog sensor and safety float switches	Analog sensor and mixer	Analog sensor, mixer and safety float switches
Analog inputs							
IO 351B-1	AI1	51	-	User-defined sensor 2	User-defined sensor 2	User-defined sensor 2	User-defined sensor 2
	AI2	54	-	User-defined sensor 3	User-defined sensor 3	User-defined sensor 3	User-defined sensor 3
Digital inputs							
IO 351B-1	DI1	10	Energy meter or flowmeter*	Energy meter or flowmeter*	Energy meter or flowmeter*	Energy meter or flowmeter*	Energy meter or flowmeter*
	DI8	44	Float switch**	-	-	-	-
	DI9	46	Float switch**	-	-	-	-
Digital outputs							
IO 351B-1	DO1	77	Start of pump 1	Start of pump 1	Start of pump 1	Start of pump 1	Start of pump 1
	DO2	79	Start of pump 2	Start of pump 2	Start of pump 2	Start of pump 2	Start of pump 2
	DO3	81	All alarm relays	All alarm relays	All alarm relays	All alarm relays	All alarm relays
	DO4	82	VFD 1, reverse	VFD 1, reverse	VFD 1, reverse	VFD 1, reverse	VFD 1, reverse
	DO5	84	VFD 2, reverse	VFD 2, reverse	VFD 2, reverse	VFD 2, reverse	VFD 2, reverse
	DO6	86	-	-	-	Mixer start	Mixer start
	DO7	88	User-defined alarms	User-defined alarms	User-defined alarms	User-defined alarms	User-defined alarms
Analog outputs							
IO 351B-1	AO1	18	-	VFD frequency, pump 1	VFD frequency, pump 1	VFD frequency, pump 1	VFD frequency, pump 1
	AO2	22	-	VFD frequency, pump 2	VFD frequency, pump 2	VFD frequency, pump 2	VFD frequency, pump 2
	AO3	26	-	-	-	-	-
PTC inputs							
IO 351B-1	PTC1	30	PTC, pump 1	PTC, pump 1	PTC, pump 1	PTC, pump 1	PTC, pump 1
	PTC2	32	PTC, pump 2	PTC, pump 2	PTC, pump 2	PTC, pump 2	PTC, pump 2

* Connect either an energy meter or a flowmeter to the IO 351B-1 (DI1).

** See section [5.3 Float switches](#).

5.3 Float switches

The CU 361 has a set of factory default settings for the float switches. The functions of the float switches depend on the number of pumps and float switches installed.

If more than two pumps are installed, only two float switches can be used, and they are used as safety high-level and/or dry-running float switches.



TM02 0670 3805

Fig. 10 Float switches

High-level and dry-running float switches

In the pit, the high-level float switch must be physically installed above the level indicated as high level, otherwise "Conflicting levels" and "Level sensor" alarms will be triggered. See fig. 11.

The dry-running float switch must be physically installed below the level indicated as dry-running level, otherwise "Conflicting levels" and "Level sensor" alarms will be triggered. See fig. 11.

Note

The alarms "Conflicting levels" and "Level sensor" will only be triggered if an analog level sensor is installed. The analog level sensor is not shown in fig. 11.

When the high-level float switch is activated, it triggers a high-level alarm. All pumps will start at the same time, but the number of starting pumps depends on the number of pumps in each pump group. For further information about pump groups, see Software description on the CD-ROM supplied with the Dedicated Controls control cabinet.

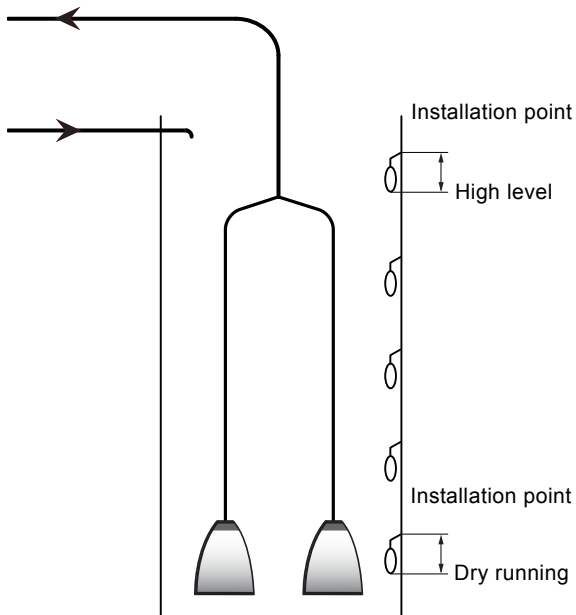

TM04 6427 0310

Fig. 11 High-level and dry-running float switches

5.4 Float switch connection

Install the float switches as recommended to ensure easy and correct installation. See fig. 12.

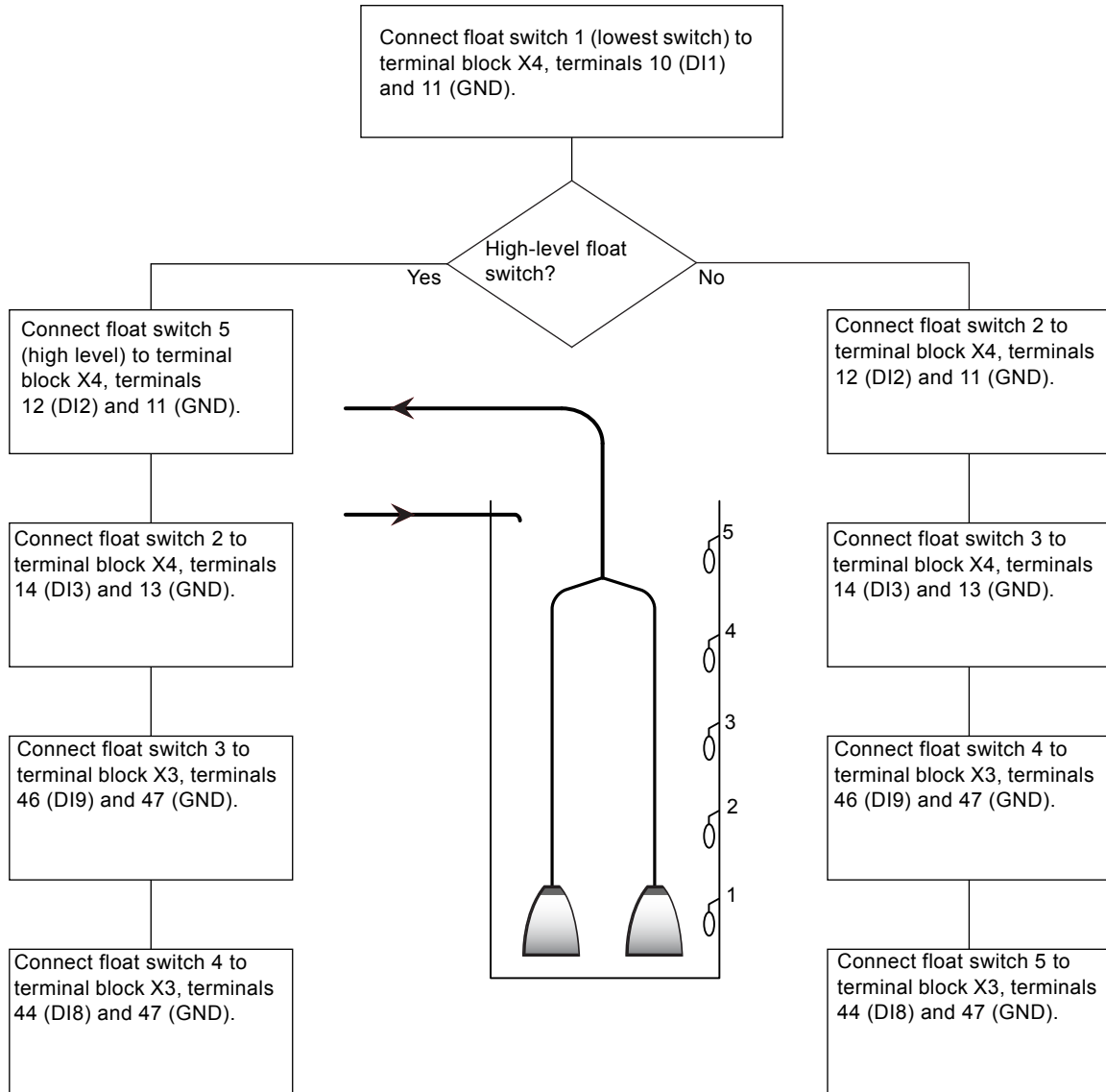

Fig. 12 Float switch installation

TM04 6428 0310

Installations with two pumps and five float switches

Example 1

Float switch	Unit/module	Terminal block	Signal (terminal)	Description
Float switch 5	CU 361	X4	DI2 (12), GND (11)	High level
Float switch 4	IO 351B-1	X3	DI8 (44), GND (47)	Stop 2
Float switch 3	IO 351B-1		DI9 (46), GND (47)	Start 1
Float switch 2	CU 361	X4	DI3 (14), GND (13)	Stop
Float switch 1	CU 361		DI1 (10), GND (11)	Dry running

Example 2

Float switch	Unit/module	Terminal block	Signal (terminal)	Description
Float switch 5	IO 351B-1	X3	DI8 (44), GND (47)	Start 2
Float switch 4	IO 351B-1		DI9 (46), GND (47)	Alarm
Float switch 3	CU 361	X4	DI3 (14), GND (13)	Start 1
Float switch 2	CU 361		DI2 (12), GND (11)	Stop
Float switch 1	CU 361		DI1 (10), GND (11)	Dry running

5.5 Analog level sensors

This section describes the most important issues concerning installation of level sensors.

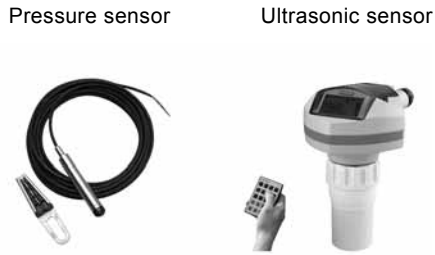

Fig. 13 Analog level sensors

Level detection can be done by an analog level sensor. We recommend the use of one of these sensors:

- pressure sensor
- ultrasonic sensor.

To ensure accurate measurements, it is important that the sensor parameters are entered correctly.

5.5.1 Pressure sensor

When a pressure sensor is used, special attention must be given to the sensor setting.

Type of control signal

- 0-20 mA
- 4-20 mA
- 0-10 V.

Measuring range

- Min. value [m]
- Max. value [m].

Note

Float switches can be used as safety high-level and dry-running float switches.

5.5.2 Ultrasonic sensor

When an ultrasonic sensor is used, special attention must be given to the sensor setting.

Type of control signal

- 0-20 mA
- 4-20 mA
- 0-10 V.

Measuring range

- Min. value [m]
- Max. value [m].

The user must state whether the measuring signal is for water depth (Δh_2) or distance from the top of the pump pit to the water level (Δh_1).

When the distance to the water level is being measured, the user must enter an "Offset". This offset gives the distance from the ultrasonic sensor to the top of the pit. Furthermore, the function "Inverted" must be selected (it is shown if an ultrasonic sensor is selected). See fig. 14.

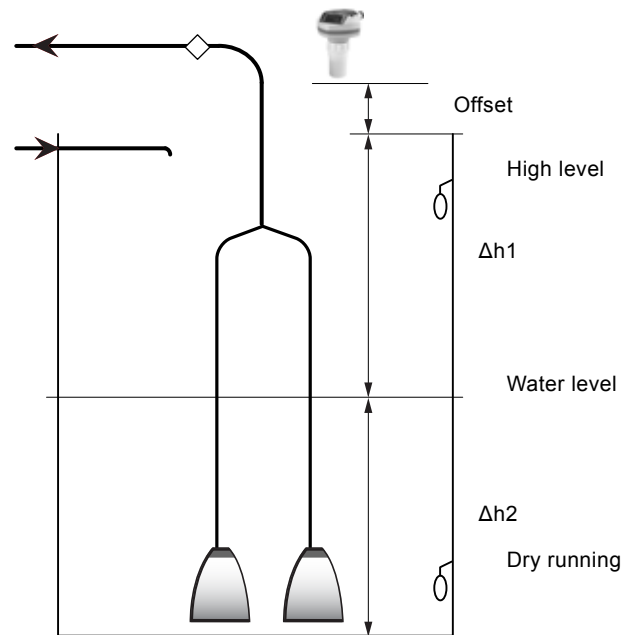

Fig. 14 Ultrasonic sensor

TM04 6431 0310

TM04 6429 0310

5.6 Communication

5.6.1 Communication between the CU 361, IO 351B, IO 111 and CUE

The CU 361 communicates with the individual modules via GENIbus. Additional modules are connected in parallel (daisy chain). See fig. 15.

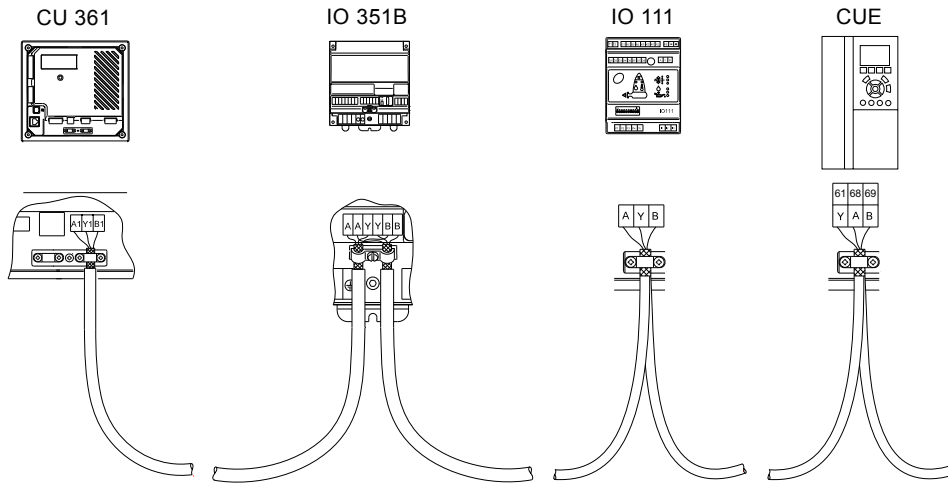

Fig. 15 GENIbus connection

5.6.2 GENIbus number (address)

If the Dedicated Controls has been ordered as a complete control cabinet, the GENIbus numbers have been factory-set.

If the modules have been ordered as separate components, it is the user's responsibility to set the GENIbus numbers.

Pump number	Unit/module		
	IO 351B*	IO 111**	CUE
1	41	9 (40)	1
2		10 (41)	2

* Three IO 351B modules can be connected to the Dedicated Controls system.

** The DIP switches on the IO 111 module must be set to bus configuration if the IO 111 module is to be configured by use of a PC Tool. See installation and operating instructions for the IO 111.

6. Commissioning

6.1 Start-up

After having carried out the mechanical, hydraulic and electrical installation, proceed as follows:

1. Switch on the power supply.
 2. Wait for the first display to appear.
 3. The first time the CU 361 is switched on, there are two options:
 - A configuration wizard guides the user through specific settings.
See section [6.3.1 Configuration by wizard](#).
 - The user configures the system by use of PC Tools.
See section [6.3.2 Configuration by PC Tools and PC Tool Link](#).
 4. Follow the instructions in each display.
- The system is now ready for operation.

6.2 Taking Dedicated Controls out of operation

Switch off the main switch to take the system out of operation.



Warning

The conductors in front of the main switch are still energised.

Lock the main switch with a padlock to ensure that it cannot be accidentally switched on.

An individual pump is taken out of operation by switching off the power supply to the corresponding motor-protective circuit breaker, automatic circuit breaker or fuse.

It is recommended to stop one pump at a time. Stopping one pump at a time minimises pressure surges in the discharge pipe.

6.3 Quick start

When the system is started up for the first time, the pumps are set to "Out of operation". This ensures that the pumps do not start until the system configuration has been completed. For information about the CU 361 operator display, see Software description on the CD-ROM supplied with the Dedicated Controls control cabinet.

The Dedicated Controls can be configured and put into operation in two ways:

- configuration by wizard
- configuration by use of PC Tools.

6.3.1 Configuration by wizard

When the system is started up for the first time, a step-by-step configuration wizard will start. This configuration wizard helps the user to configure the system. When the configuration is completed, the system is ready for operation.



Fig. 16 Configuration by wizard

Help ?

Press ? to display the relevant help text. All the elements in the display have a selectable help text.

Wizard display setting	Description
Display language	Select the desired language.
Welcome	-
Date and time	Set date and time.
Units	Select units.
Installation name	Enter the installation name.
Primary settings	Select the settings required.
Modules installed	Select the modules installed.
Float switch function	Select float switch function. See section 5.4 Float switch connection .
Set up level sensor	Select the type of level sensor installed. See section 5.5 Analog level sensors .
Analog inputs	Set the analog inputs. See section 6.4.1 Analog inputs .
Start and stop levels	Enter start and stop levels.
Warning	-
Pump and system options	-
Digital inputs	Set the digital inputs. See section 6.5.2 Digital inputs .
Communication settings	Select and set up the communication. See section 6.3.3 Communication .
Configuration completed	The system configuration is completed, and the system is ready for operation. To set up advanced functions, see Software description on the CD-ROM supplied with the Dedicated Controls control cabinet.

TM04 6455 0610

CU 361 factory settings

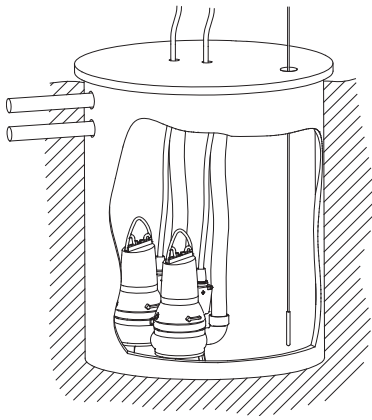

TM02 8305 1704

Fig. 17 Example of a two-pump installation (factory settings)

Pit dimension	
Pit depth	5.0 m
Levels	
Overflow level	4.95 m
High level	4.75 m
Alarm level	3.5 m
Start level 2	2.0 m
Start level 1	1.75 m
Stop level 1	0.5 m
Stop level 2	0.5 m
Dry-running level	0.25 m
Foam-draining level	0.15 m
Upper measurement level	1.5 m
Lower measurement level	0.5 m
Max. measurement time	3,600 sec.
Analog sensor	4-20 mA, 0-5 m

6.3.2 Configuration by PC Tools and PC Tool Link

For the physical connection between the PC and Dedicated Controls (CU 361), a Grundfos PC Tool Link is used. This converts the RS-485 used by Dedicated Controls to USB used by the PC. The PC Tool Link also provides a galvanic separation between the PC and Dedicated Controls.

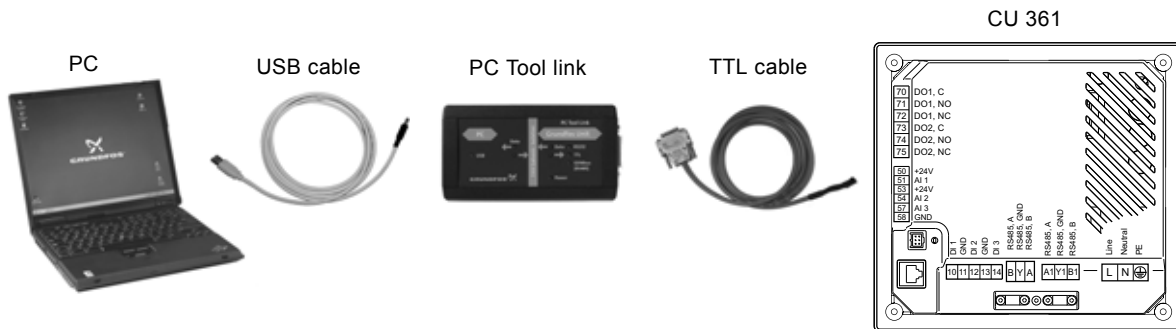

Fig. 18 Configuration by PC Tools

Load the PC Tool WW Controls, and configure the system direct on line, or upload a prepared configuration file to the CU 361.

TM04 7125 1510

When the system has been set up by use of PC Tools, the power supply to the control cabinet and each pump must be switched on. We recommend you to set the Auto/On/Off switch to position "Auto". See fig. 19.

Note

If the Auto/On/Off switch is set to position "On", the Dedicated Controls system cannot be set or managed by the SCADA system.



Fig. 19 Auto/On/Off switch

6.3.3 Communication

Go to the menu Settings > Communication settings.

The CU 361 must have a CIM module (Communication Interface Module) fitted to be able to transfer data to the SCADA system or to a mobile phone.

Various CIM modules are available, depending on the type of network. The CIM module must be fitted directly in the CU 361. See installation and operating instructions for the CU 361.

For configuration of the CIM module, see the installation and operating instructions and the functional profile on the CD-ROM supplied with the module.

6.3.4 Selecting the CIM communication module

In this display, the CIM communication module fitted in the CU 361 must be selected.

Select each of the submenus, and enter the data required in each menu. For further information, see the Software description on the CD-ROM supplied with the Dedicated Controls control cabinet.

Each communication module has a series of configuration submenus and special functions.

The CU 361 supports these CIM modules:

- CIM 200 (Modbus RTU via RS-485)
- CIM 250 (Modbus TCP and SMS via GSM/GPRS)
- CIM 270 (GRM = Grundfos Remote Management)
- Other module (future communication modules).

Note

The type of communication module used can be found on the back of the CU 361.

Path: Settings > Communication settings >

Status	Operation	Alarm	Settings
4.3 - Communication settings			
Select the communication module installed			
No module			<input type="checkbox"/>
CIM 200			<input type="checkbox"/>
CIM 250			<input checked="" type="checkbox"/>
CIM 270			<input type="checkbox"/>
Other module			<input type="checkbox"/>
Select submenu			
Ethernet			
Fieldbus addresses			
SMS numbers			
SMS schedule			
SMS heartbeat message			
SMS authentication			
GSM and SIM card settings			
SCADA settings			
Interlock settings			
GPRS settings			
GRUNDFOS		2010-09-22 12:43	

Display_4.3

Fig. 20 Communication settings

Note

The SIM card PIN code must be set to 4321 before the CIM 270 can establish communication with a GSM network.

Change the PIN code by inserting the SIM card into a mobile phone. Consult your mobile phone manual for further details.

Configuration via network

When the CIM module fitted in the CU 361 has been configured, the remaining configuration can be done using the established communication line.

6.3.5 CUE or VFD installations

For details about the setup of the CUE and VFD, see the Software description on the CD-ROM supplied with the Dedicated Controls control cabinet.

Radio modem

If a radio modem is to be used as communication line, a CIM 200 Modbus module must be fitted in the CU 361.

The following has to be set:

- Modbus address
- Parity
- Modbus transmission speed.

See installation and operating instructions for the CIM 2XX Modbus module.

The Modbus address set in the CIM 200 Modbus module has to be set in the CU 361 as well.

1. Select "CIM 200".
2. Select the submenu "Fieldbus addresses".
3. Set the Modbus address in the line "CIM Modbus address".

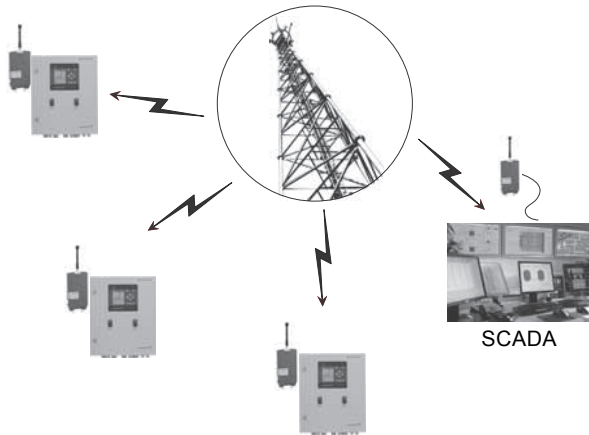
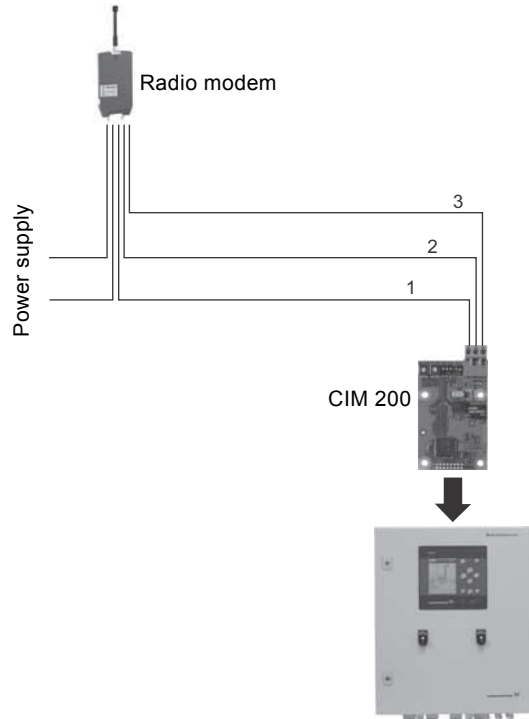

Fig. 21 Radio modem network

TM04 6490 0410

The connection between the radio modem and the CIM 200 Modbus module is established by using an RS-485 serial cable.



TM04 6992 1310

Fig. 22 Radio modem connection via Modbus RTU

Pos.	Designation	Description
1	Common/GND	Modbus terminal Common/GND
2	D0	Modbus terminal D0 (negative data signal)
3	D1	Modbus terminal D1 (positive data signal)

6.4 I/O settings

This section describes how to set up inputs, outputs and alarm relays.

The displays shown in the following sections are to be regarded as examples.

Note *The display shown may differ from the current display on the CU 361 as the display depends on the installed components and the actual configuration of the system.*

This display shows the options in the I/O settings menu.

Path: Settings > I/O settings >

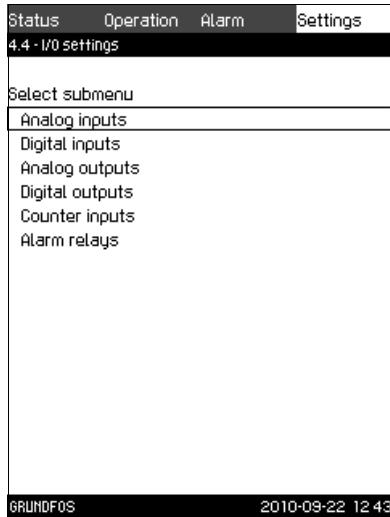

Display_4.4

Fig. 23 I/O settings

6.4.1 Analog inputs

The analog input to be set is selected in this display.

As standard, there are five analog inputs. The display shows each input so that its physical location can be quickly identified.

Example

The AI1 analog input on the CU 361 (designated terminal 51) is linked to the function "Level, pressure".

AI1 (CU 361) [51] and AI1 (IO 351B-41) [57].

Input	Control unit/module	Terminal
AI1	CU 361	51
AI1	IO 351B	57

Path: Settings > I/O settings > Analog inputs >

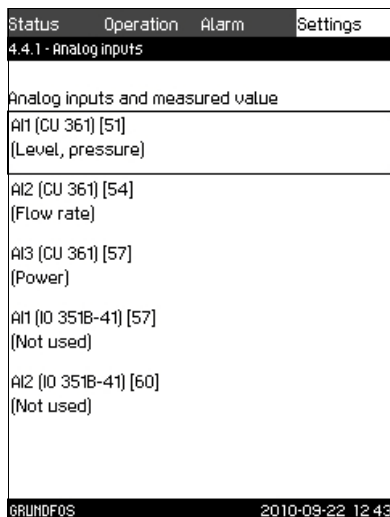

Display_4.4.1

Fig. 24 Analog inputs

Analog input, configuration

The analog input to be set is selected in this display.

Each analog input has its own display. The number of displays depends on the number of analog inputs.

Example

1. Select input signal type, e.g. 4-20 mA.
2. Select input value, e.g. "Level, pressure".
3. Set sensor measuring range (minimum and maximum limits), e.g. 0.0 to 5.0 m.

Note *If an analog input is disabled, the display will only show the upper part, i.e. the input setting.*

If the input is enabled, "Measured input value" is shown.

A function can be linked to an analog input in another display.

The CU 361 will return to the analog input setting display.

Path: Settings > I/O settings > Analog inputs > Analog inputs >

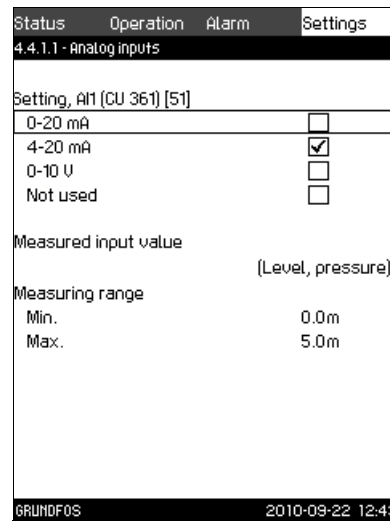

Display_4.4.1.1

Fig. 25 Analog inputs

Analog inputs, input value

The input value for the selected analog input is set in this display.

Path: Settings > I/O settings > Analog inputs > Analog inputs > Analog inputs and measured value >

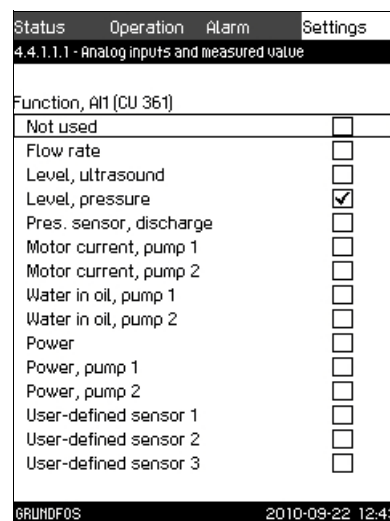

Display_4.4.1.1.1

Fig. 26 Analog inputs and measured value

6.4.2 Digital inputs

The digital input to be set is selected in this display. As standard, there are 12 digital inputs. The display shows each input so that its physical location can be quickly identified.

Example

The DI2 digital input on the IO 351B (designated terminal 12) is linked to the function "Contactor feedback, pump 1", and the contactor type is normally open.
DI1 (CU 361) [10] and DI2 (IO 351B-41) [12].

Input	Control unit/ module	Terminal
DI1	CU 361	10
DI2	IO 351B	12

Path: Settings > I/O settings > Digital inputs >

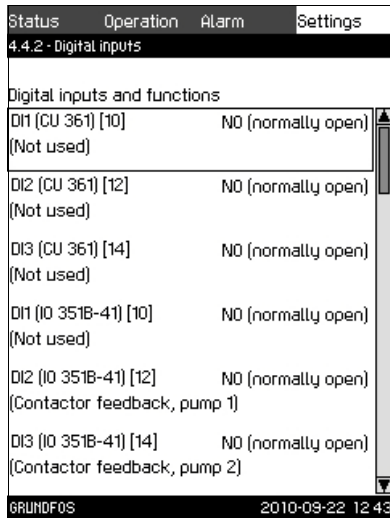

Display_4.4.2

Fig. 27 Digital inputs

Digital inputs and functions

The signal input logic and the digital input function are set in this display.

Path: Settings > I/O settings > Digital inputs > Digital inputs and functions >

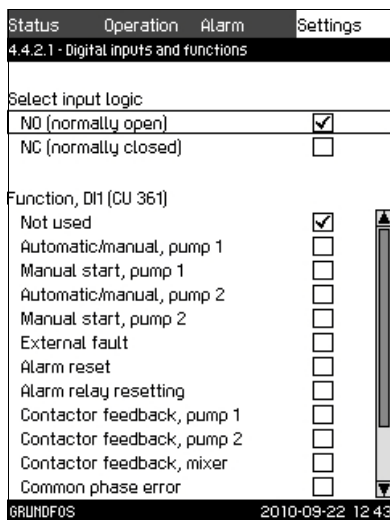

Display_4.4.2.1

Fig. 28 Digital inputs and functions

6.4.3 Analog outputs

The analog output to be set is selected in this display. As standard, there are three analog outputs. The display shows each output so that its physical location can be quickly identified.

Example

The AO1 analog output on the IO 351B (designated terminal 18) is linked to the function "VFD frequency, pump 1".
AO1 (IO 351B-41) [18].

Input	Module	Terminal
AO1	IO 351B	18

Path: Settings > I/O settings > Analog outputs >

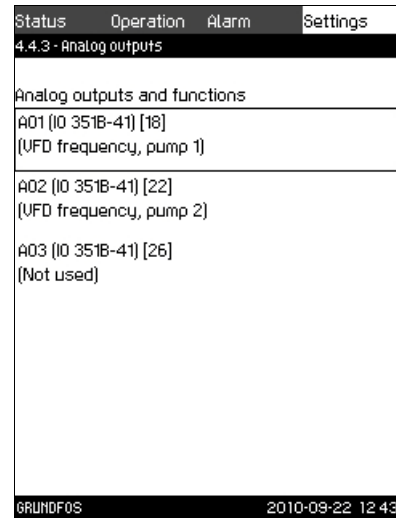

Display_4.4.3

Fig. 29 Analog outputs

6.4.4 Digital outputs

The digital output to be set is selected in this display.

As standard, there are nine digital outputs. The display shows each digital output so that its physical location can be quickly identified.

Example

The DO1 digital output on the CU 361 (designated terminal 71) is linked to "High-level alarm".

DO1 (CU 361) [71] and DO1 (IO 351B-41) [77].

Output	Control unit/ module	Terminal
DO1	CU 361	71
DO1	IO 351B	77

Path: Settings > I/O settings > Digital outputs >

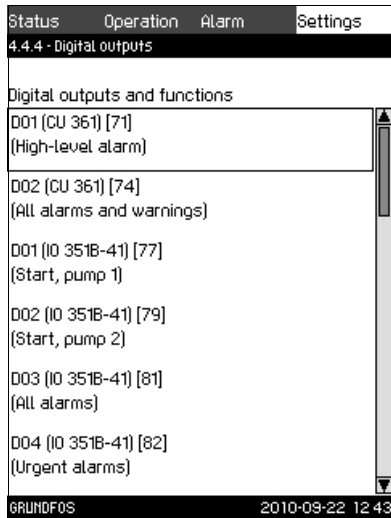

Fig. 30 Digital outputs

Digital outputs, output value

The output value for the selected digital output is set in this display.

Example

The DO1 digital output on the CU 361 (designated terminal 71) is linked to "High-level alarm".

Path: Settings > I/O settings > Digital outputs > Function of digital outputs >

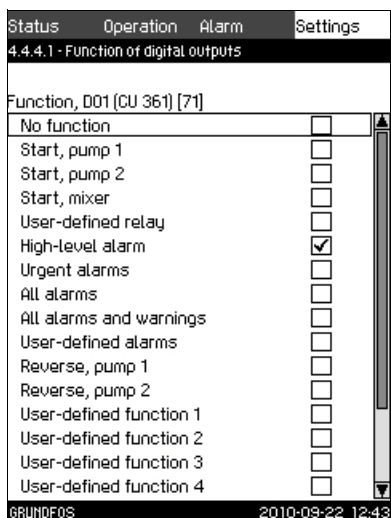

Fig. 31 Function of digital outputs

6.4.5 Counter inputs

The counter input to be set is selected in this display.

A counter input can connect to a flowmeter or energy meter.

As standard, there are two counter inputs. Each counter can be set via a submenu.

Path: Settings > I/O settings > Counter inputs >

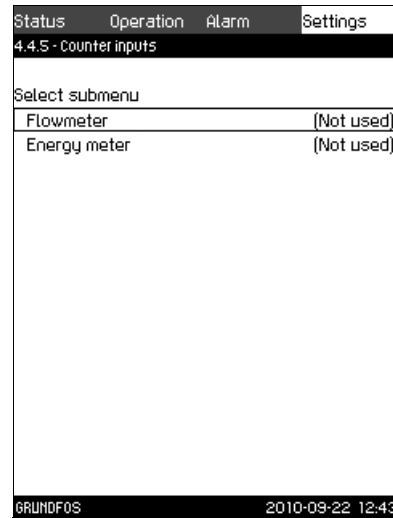

Fig. 32 Counter inputs

Counter inputs, configuration

The selected counter input is set in this display.

1. Identify the digital input connected to a flowmeter in the system.
2. Select the digital input the flowmeter is connected to, unit and scaling.

Note

The IO 351B pulse input has a maximum frequency of 12 Hz.

Path: Settings > I/O settings > Counter inputs > Flowmeter >

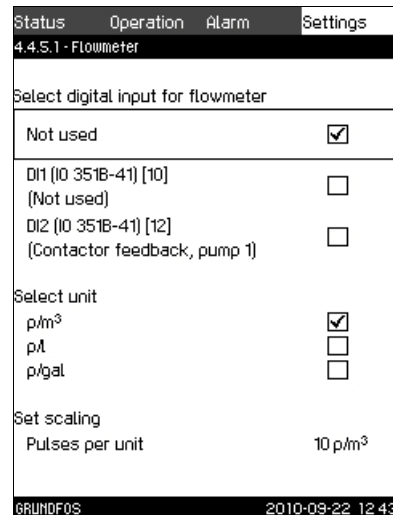

Fig. 33 Flowmeter

Display_4.4.5

Display_4.4.4

Display_4.4.1

Display_4.4.5.1

6.5 Electrical overview

This display shows an overview of the various inputs and outputs. The submenus in this display are described in the following sections.

Path: Status > Electrical overview >

Status	Operation	Alarm	Settings
1.10 - Electrical overview			
Select submenu			
Analog inputs			
Digital inputs			
Analog outputs			
Digital outputs			
User-defined functions			
GRUNDFOS 2010-09-22 12:43			

Fig. 34 Electrical overview

6.5.1 Analog inputs

This display shows the status of the individual analog inputs.

Example

Analog input AI1 (CU 361) [51]:

The AI1 analog input on the CU 361 (designated terminal 51) is set up as a current input.

The measured value of 14.9 mA corresponds to a level and a pressure of 3.40 m.

Path: Status > Electrical overview > Analog inputs >

Status	Operation	Alarm	Settings
1.10.1 - Analog inputs			
Analog inputs and measured value			
AI1 (CU 361) [51] (Level, pressure)			14.9mA 3.40m
AI2 (CU 361) [54] (Flow rate)			4.8mA 1.0m ³ /h
AI3 (CU 361) [57] (Not used)			-- --
AI1 (IO 351B-41) [57] (Not used)			-- --
AI2 (IO 351B-41) [60] (Not used)			-- --
GRUNDFOS 2010-09-22 12:43			

Fig. 35 Analog inputs

Note

If an ultrasonic sensor is used, this display only shows the "raw" value without offset and not inverted.

6.5.2 Digital inputs

This display shows the status of the individual digital inputs.

Example

Digital input DI2 (IO 351B-41) [12]:

The DI2 digital input on the IO 351B (designated terminal 12) is linked to the function "Contactor feedback, pump 1", and the contact is closed.

Path: Status > Electrical overview > Digital inputs >

Status	Operation	Alarm	Settings
1.10.2 - Digital inputs			
Digital inputs and functions			
DI1 (CU 361) [10] (Not used)			<input type="checkbox"/>
DI2 (CU 361) [12] (Not used)			<input type="checkbox"/>
DI3 (CU 361) [14] (Not used)			<input type="checkbox"/>
DI1 (IO 351B-41) [10] (Not used)			<input type="checkbox"/>
DI2 (IO 351B-41) [12] (Contactor feedback, pump 1)			<input checked="" type="checkbox"/> Active
DI3 (IO 351B-41) [14] (Contactor feedback, pump 2)			<input type="checkbox"/> Not active
GRUNDFOS 2010-09-22 12:43			

Fig. 36 Digital inputs

6.5.3 Analog outputs

This display shows the status of the individual analog outputs.

Example

Analog output AO1 (IO 351B-41) [18]:

The AO1 analog output on the IO 351B (designated terminal 18) is linked to the function "VFD frequency, pump 1", and the analog output signal is 10.0 V equal to 50.0 Hz.

Path: Status > Electrical overview > Analog outputs >

Status	Operation	Alarm	Settings
1.10.3 - Analog outputs			
Analog outputs and functions			
AO1 (IO 351B-41) [18] (VFD frequency, pump 1)			10.0V 50.0Hz
AO2 (IO 351B-41) [22] (VFD frequency, pump 2)			0.0V 0.0Hz
AO3 (IO 351B-41) [26] (Not used)			0.0V --
GRUNDFOS 2010-09-22 12:43			

Fig. 37 Analog outputs

6.5.4 Digital outputs

This display shows the status of the individual digital outputs.

Example

Digital output DO1 (CU 361) [71]:

The DO1 digital output on the CU 361 (designated terminal 71) is linked to "High-level alarm", and the relay is active.

Path: Status > Electrical overview > Digital outputs >

Status	Operation	Alarm	Settings
1.10.4 - Digital outputs			
Digital outputs and functions			
DO1 (CU 361) [71] (High-level alarm)			Active
DO2 (CU 361) [74] (All alarms and warnings)			Active
DO1 (IO 351B-41) [77] (Start, pump 1)			Not active
DO2 (IO 351B-41) [79] (Start, pump 2)			Not active
DO3 (IO 351B-41) [81] (All alarms)			Active
DO4 (IO 351B-41) [82] (Urgent alarms)			Active
GRUNDFOS 2010-09-22 12:43			

Display_1.10.4

Fig. 38 Digital outputs

6.5.5 User-defined functions

This display shows all functions (up to eight) defined by the user. Each user-defined function is shown with two sources and the selected functions. In the top right corner of each user-defined function, the actual status is shown (Active/Not active).

See Software description on the CD-ROM supplied with the Dedicated Controls control cabinet.

Example

"User-def. function 1" has been activated by the 1st source, which has been set to "Constantly high". The 2nd source has also been set to "Constantly high".

"User-def. function 1" is linked to a digital output.

See Software description on the CD-ROM supplied with the Dedicated Controls control cabinet.

Path: Status > Electrical overview > User-defined functions >

Status	Operation	Alarm	Settings
1.10.5 - User-defined functions			
User-defined functions and inputs			
User-defined function 1 (Constantly high)			Active
(Constantly high)			Active
My function (All pumps running)			Not active
(Timer function)			Not active
Leakage detected (AI2 (IO 351B-41) [60])			Active
(Constantly high)			Active
Run ventilation (Constantly high)			Active
(DI1 (CU 361) [10])			Active
User-defined function 5 (Constantly high)			Not active
GRUNDFOS 2010-09-22 12:43			

Display_1.10.5

Fig. 39 User-defined functions

7. Maintenance



Warning

Before starting work on the pumps, make sure that the power supply has been switched off. Lock the main switch with a padlock to ensure that it cannot be accidentally switched on.

7.1 CU 361

The CU 361 is maintenance-free. It should be cleaned with a dry or wet cloth. Protect it from direct sunlight. Furthermore, the CU 361 temperature must not be outside the ambient temperature range. See section 9. [Technical data](#).

8. Fault finding



Warning

Before making any connections in pumps, terminal boxes or control cabinet, make sure that the power supply has been switched off for at least 5 minutes and that it cannot be accidentally switched on.

Fault	Cause	Remedy
1. Pumps do not run when started.	a) CU 361 fault.	• Reset alarms, or replace the CU 361.
	b) Power supply disconnected.	• Switch on the power supply. • Replace fuse. • Replace the main switch.
	c) Main switch cut out.	• Cut in the main switch.
	d) Main switch defective.	• Replace the main switch.
	e) Motor protection tripped.	• Check the setting.
		• Motor defective (contact Grundfos).
		• Open thermistor.
		• Phase failure.
		• Contact Grundfos.
	f) Motor defective.	• Repair or replace the motor.
	g) Sensor fault.	• Check sensor configuration. • Replace the sensor.
h) Cable defective.	• Repair or replace the cable.	
i) No water in pump pit.	• Wait until the level control activates a pump.	
j) Level control fault.	• Check level control configuration.	
	• Replace the sensor/float switch.	
k) External on/off switch switched off.	• Switch on the on/off switch.	
2. Pumps start, but stop immediately.	a) Dry running or no inlet pressure.	• Wait until the level control activates a pump.
	b) Motor protection tripped.	• Check the setting. • Motor defective (contact Grundfos).
	c) Level control fault.	• Check level control configuration. • Replace the sensor/float switch.
3. Pump performance unstable.	a) Suction port blocked by impurities.	• Clean the pump.
	b) Suction pipe or pumps partially blocked by impurities.	• Clean the suction pipe, strainer or pumps.
	c) Pumps suck air.	• Incorrect positioning of pump relative to level control (dry running).
	d) Valves closed.	• Open the valves.
4. Pumps are running, but deliver no water.	a) Valves closed.	• Open the valves.
	b) Suction pipe or pumps blocked by impurities.	• Clean the suction pipe or pumps.
	c) Non-return valve blocked in closed position.	• Clean the non-return valve. The non-valve must be able to move freely.
5. Pumps start and stop frequently.	a) Incorrect distance between start and stop levels.	• Set start and stop levels correctly.

9. Technical data

Altitude above sea level

Maximum 2,000 m.

Ambient temperature

- During operation: 0 °C to +50 °C
(must not be exposed to direct sunlight).
At temperatures below 0 °C, the display may react slowly.
- In stock: -20 °C to +60 °C.
- During transportation: -20 °C to +60 °C.

Relative air humidity

5 to 95 %.

Enclosure class

IP54.

10. Electrical data

Supply voltage

See nameplate on Dedicated Controls.

Backup fuse

See the wiring diagram supplied with the Dedicated Controls system.

Digital inputs

Open-contact voltage	24 VDC
Closed-contact current	5 mA, DC
Frequency range	0-4 Hz

Note

All digital inputs are supplied with PELV voltage (Protective Extra-Low Voltage).

Analog inputs

Input current and voltage	0-20 mA 4-20 mA 0-10 V
Tolerance	± 3.3 of full scale
Repetitive accuracy	± 1 % of full scale
Input resistance, current	< 250 Ω
Input resistance, voltage, CU 361	> 50 kΩ ± 10 %
Input resistance, voltage, IO 351B	> 50 kΩ ± 10 %
Sensor supply	24 V, 30 mA, short-circuit-protected

Note

All analog inputs are supplied with PELV voltage (Protective Extra-Low Voltage).

Digital outputs (relay outputs)

Maximum contact load	240 VAC, 2 A
Minimum contact load	5 VDC, 10 mA

All digital outputs are potential-free relay contacts.

Some outputs have a common C terminal.

Note

For further information, see the wiring diagram supplied with the Dedicated Controls system.

Inputs for PTC sensor/thermal switch

For PTC sensors to DIN 44082. A thermal switch can also be connected.

Open-circuit voltage	12 VDC ± 15 %
Closed-circuit current	2.6 mA, DC

Note

Inputs for PTC sensors are electrically separated from the other inputs and outputs of the Dedicated Controls system.

11. Disposal

This product or parts of it must be disposed of in an environmentally sound way:

1. Use the public or private waste collection service.
2. If this is not possible, contact the nearest Grundfos company or service workshop.

97726036 0910

GB

ECM: 1065473

The name Grundfos, the Grundfos logo, and the payoff Be-Think-Innovate are registered trademarks owned by Grundfos Management A/S or Grundfos A/S, Denmark. All rights reserved worldwide.